



ROPS/FOPS cab and canopy

Superior protection is provided by a Roll-Over Protective Structure and Falling Object Protective Structure. Both ROPS and FOPS meet the strictest ISO standards. To let you work longer and with less fatigue, our cab is spacious and comfortable.



Fully adjustable suspension seat

To provide a high level of comfort to a wide range of operators, the suspension seat adjusts according to the operator's weight, plus has hip support and recline. A retractable safety belt ensures operator safety.

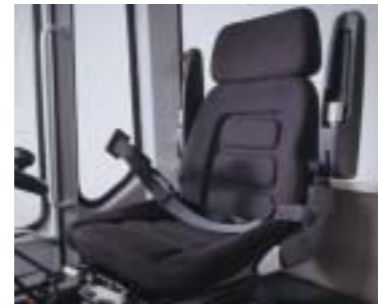

Lower sound and vibration

To enhance operator comfort, the Kubota R420 and R520 utilise a new engine mount design, a helical gear, and an F-shaped fan to significantly reduce overall noise and vibration.

SPECIFICATIONS

Model		R420	R520	
Engine	Model	Kubota		
	Type	D1503-M-T-E2RP-1	V2203-M-E2RP	
	Output	kW/rpm	29/2600	33/2600
		PS/rpm	40/2600	45/2600
	Number of cylinders	3	4	
	Displacement	cc	1499	2197
Dimensions	Overall height (canopy/cabin)	mm A	2615/2570	2685/2640
	Overall length	mm B	4430	4740
	Overall width	mm C	1520	1760
	Height to hinge pin	mm D	2810	3310
	Dump angle fully raised	E	43 °	41 °
	Dump height	mm F	2110	2580
	Reach fully raised	mm G	770	
	Wheelbase	mm H	1775	1950
	Ground clearance	mm I	280	325
	Tread	mm J	1180	1270
Operational Specifications (with standard bucket)	Angle of articulation (each way)	K	40 °	
	Standard bucket capacity	m ³	0,40	0,57
	Bucket breakout force	daN (kgf)	2920 (2980)	3310 (3375)
	Tipping Load, straight (ISO 8313) (canopy/cab)	kg	2000/2370	2590/2920
	Tipping Load, full turn (ISO 8313) (canopy/cab)	kg	1700/2010	2200/2480
	Max. Lifting Capacity (ISO 8313)	daN (kgf)	1770 (1800)	2320 (2370)
	Loader raise time	sec	4,4	4,5
	Loader lower time	sec	3,7	3,6
	Bucket dump time	sec	1,2	
	Draw bar pull	daN (kgf)	2350 (2400)	3140 (3200)
Operational Specifications (with fork)	Operating weight (canopy/cabin)	kg	3040/3360	3980/4300
	with backhoe (canopy/cab)	kg	3380/3700	3800/4120
	Standard tires		12,5/70-16-8PR	15,5/60-18-8PR
Operational Specifications (with fork)	Tipping Load, full turn (ISO 8313)	kg	1240/1460	1420/1970
	Max. Payload (EN474-3) 80%	kg	950/1150	1100/1550
Operational Specifications (with fork)	Max. Payload (EN474-3) 60%	kg	700/850	850/1150
	Transmission		Load Sensing Transmission	
Drive train	Travel speed	km/h	0 - 20	
	Brakes	Service	Enclosed, Self adjusting Wet Disc	
Parking		Spring Applied, Hydraulic Released Wet Disc		
Fluid refill	Fuel tank	ℓ	54	
	Hydraulic system	ℓ	60	62
	Hydraulic reservoir	ℓ	42	
Backhoe Specifications	Reach from centerline of swing pivot	mm A	3700	
	Overall operating height	mm B	3220	
	Loading height	mm C	2040	
	Digging depth (Maximum)	mm D	2750	
	Side shift	mm	1000	
Backhoe Specifications	Digging force bucket	kg	1860	
	Digging force dipperstick cylinder	kg	1250	

NOTE : Above dimensions are based on the machine with Quick Coupler made in Germany, Standard Bucket, Weight and ROPS/FOPS Canopy and Cab. Mean Value and value for use on concrete roads are given for tipping load and operating load. Specifications Subject to change without Notice.

WORKING RANGE

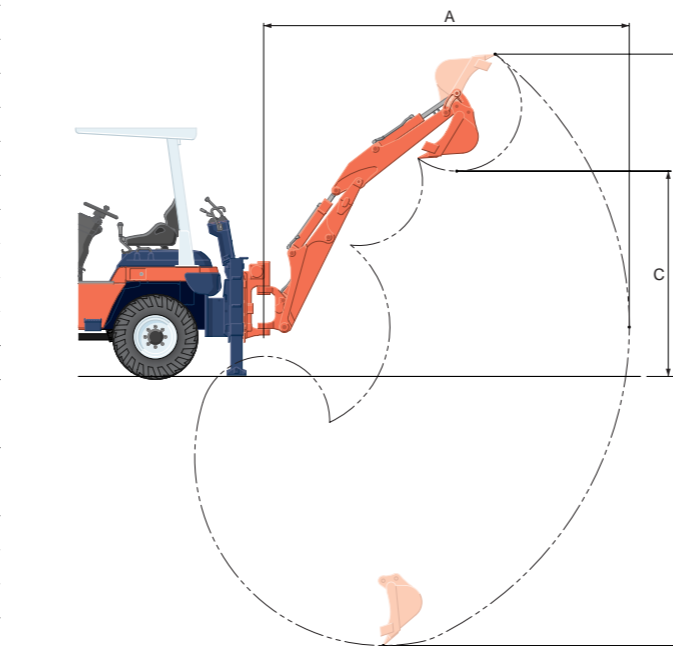
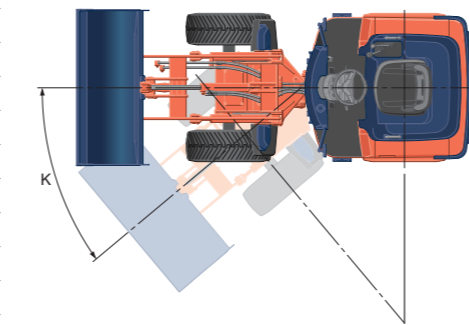
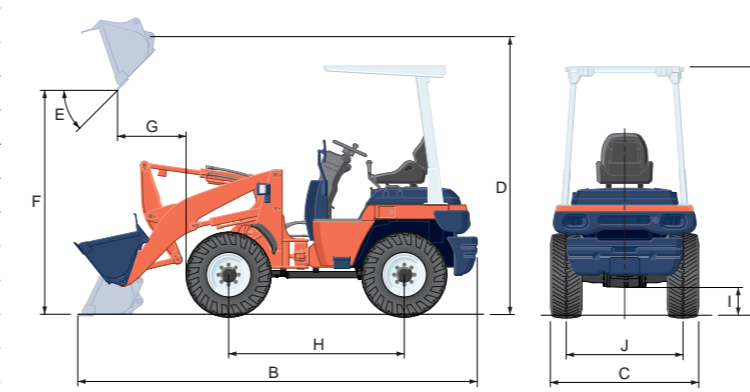

KUBOTA WHEEL LOADER

R420α/R520α



KUBOTA EUROPE S.A.

19 à 25, Rue Jules - Vercurryse - Z.I.
B.P. 88, 95101 Argenteuil Cedex France
Téléphone : (33) 01 34 26 34 34
Télécopieur : (33) 01 34 26 34 99

Powerful, versatile, and comfortable, our wheel loaders deliver optimum performance across a range of applications.

You name it—loading, backfilling, dozing, grappling, plowing, scraping—and the R420 and R520 wheel loaders can handle it. Enabling them to take on the widest range of jobs is a host of innovative features. Features such as power steering and compact size for easy navigation of any hard-to-reach site. A high reach and dump clearance, plus self-levelling bucket for easy and efficient operation. An oscillating body, long wheelbase, and limited slip differential for greater stability and stronger traction. Not to mention comfortable and safe operation with features such as a suspension seat, unobstructed visibility, low sound/vibration levels, ROPS/FOPS, lever locks, and more.



Highest dumping clearance
For easy dumping, even into trucks with high beds, the Kubota R420 and R520 have one of the highest dumping clearances in their class.

Self-levelling bucket
For smooth, efficient operation of the bucket, this innovative feature enables the bucket to automatically level itself whenever it's being lowered—eliminating the need for precise adjusting.



Independent 2-system-type brake
A hydraulic main brake and a mechanical-type parking brake offer a high level of control. To ensure responsiveness even in mud, their wet-discs are protected by being completely sealed.

Load sensing transmission with low-speed hold switch
This feature enables our wheel loaders to automatically shift from low speed/high torque to high speed/low torque as load conditions vary. For optimal operation in tight spaces, the travel speed limiter reduces maximum travel speed with just a touch of a button, while maintaining full performance of the auxiliary hydraulics.



Responsive power steering
You'll work longer and manoeuvre easier, even in tight spaces, with smooth-operating, light-touch power steering.



Automatic parking brake
This safety feature automatically engages the parking brake whenever the engine is turned off. Particularly useful when our wheel loaders are parked on steep slopes or transported by truck.



Hanging-style foot pedals
For increased foot space and a cleaner floorboard appearance, the Kubota R420 and R520 wheel loaders are equipped with hanging-style foot pedals.



Kubota M-type engine
Kubota's E-TVCS engine combines a dual-element air cleaner for enhanced durability and environmentally-friendly operation* with all the impressive qualities that have always been associated with the Kubota name—impressive power, high reliability, fuel efficiency, and low vibration.
* Complies with E.P.A. Tier II standards.

Exceptional serviceability
From simple daily maintenance to more complex repairs, a lockable, wide-opening, flip-up engine cover provides easy access to most areas of the wheel loader's engine. Standard engine features include a dual element air cleaner and a water separator.



Safety Starting System
To prevent mishaps, our Safety Start System will not allow the engine to start until the electric shuttle shift is in neutral and the parking brake is applied.



Long wheelbase
A long wheelbase, plus an oscillating body, enables the machine to keep its traction force more stable even on rough terrain, so jobs can be performed more comfortably.

Limited Slip Differential
Kubota's 4WD lets you outmuscle challenging terrain, such as mud and sand. And if one front wheel loses grip, the limited slip differential transfers that wheel's power to the opposite wheel to restore traction.

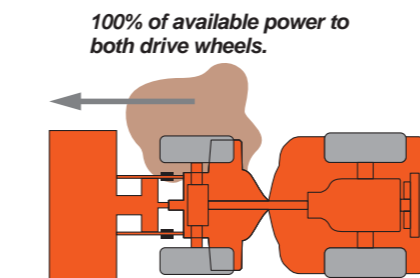

Backhoe
Quick couplers and auxiliary hydraulics make it simple to attach numerous versatile attachments, such as a backhoe, and more.

Auxiliary hydraulics—a standard feature
With the hydraulic valve and the control lever built-in, you'll save time and money whenever you need to hook up a hydraulically operated attachment.

100% of available power to both drive wheels.